

A MASTER'S GUIDE TO:

CONTAINER SECURING



CONTENTS

<u>01</u>	Voorwoord / Introduction	3
<u>02</u>	Basic advice	4
<u>03</u>	Do's and don'ts	7
<u>04</u>	Lashing systems	9
<u>05</u>	Safe working	12
<u>06</u>	Ships	15
<u>07</u>	Containers	21
<u>08</u>	Container construction	26
<u>09</u>	Lashing components	31
<u>10</u>	Principles of stowage	36
<u>11</u>	Ship's behaviour	46
<u>12</u>	Consequences of failure	51

01 VOORWOORD

De NNPC heeft zich ten doel gesteld haar loss prevention beleid aan te scherpen. Een van de onderdelen van dit beleid is het beter informeren van leden over specifieke loss prevention onderwerpen om hiermee schadeclaims te voorkomen. De herverzekeraars waar de NNPC nauw mee samenwerkt beschikken over een reeks aan loss prevention publicaties die ook voor NNPC leden relevant zijn. De NNPC heeft van The Standard P&I Club de rechten verkregen om hun publicaties ook aan NNPC leden aan te bieden. We hebben er voor gekozen, gezien de Engelse terminologie die in de praktijk vaak wordt toegepast, de publicaties voorsnóg in het Engels aan te bieden en niet te vertalen naar het Nederlands. De eerste NNPC Master's guide die we publiceren heeft als onderwerp Container Securing. Het doel van deze Master's guide is de do's en don'ts bij de bevestiging van containers aan de orde te stellen en het geven van adviezen om hiermee schades terug te brengen dan wel te voorkomen. Het streven is dat er op termijn meer publicaties gaan volgen.

FOREWORD

An improved policy on loss prevention is one of the objectives NNPC has decided to aim for. This includes providing better information to members about specific loss prevention topics in order to avoid claims.

The reinsurers with whom NNPC has a close working relationship have published a great deal of information on loss prevention that is also relevant to NNPC members. Having acquired the rights from The Standard P&I Club, NNPC is now in a position to offer these publications to its members. As English terminology is quite common in our industry we have decided to make the original English documents available instead of having them translated into Dutch.

Our first NNPC Master's Guide is all about Container Securing. It highlights the do's and don'ts of container securing and offers tips and advice which will enable you to reduce or prevent loss.

We intend to publish more Master's Guides in due course.

*NNPC, Expertise bv
Gijs Lindenburg*

02 BASIC ADVICE

There are certain actions that should always be taken to prevent containers from being damaged or lost overboard. The following steps are considered best practice.

POINTS TO REMEMBER

- check stack weights before stowage. It is important not to exceed allowable stack weights; otherwise failure of the corner posts of the containers stowed at the bottom of the stack is possible. If the stow is too heavy, the lashings may have insufficient strength to hold the containers in place if bad weather is encountered
- never deviate from the approved lashing arrangements shown in the Cargo Securing Manual, except to add additional lashings. Calculate forces using the approved loading computer
- discuss the proposed loading with stevedores to ensure that the proposed loading does not compromise the ship's lashing system, loading requirements or stability
- consult the Cargo Securing Manual before applying lashings
- if stack weights are high and bad weather is expected, then fit additional lashings
- try to avoid isolated stacks of containers in holds or on deck. Where possible, load containers so they are evenly distributed
- avoid loading heavy containers above light containers and at the top of a stack, unless the stowage arrangement is shown in the Cargo Securing Manual and the stowage is found satisfactory when checked using the approved loading computer
- avoid carrying open frame containers in cargo holds unless specifically permitted in the Cargo Securing Manual
- keep your system of lashing simple, using the highest rated components
- to assist the shore lashing gang, give them precise instructions as to how containers should be secured
- examine containers for physical defects – check the corner posts carefully. The corner posts have to resist high compression forces as a result of static weights from containers stowed on top

and from dynamic forces that occur when the ship rolls, heaves and pitches. Containers with damaged corner posts placed in the bottom of a stow are likely to collapse. Reject damaged containers

- check that all cell guides are clear of obstacles, are straight and are not buckled
- check that turnbuckles are fully tightened. Loose lashings will be ineffective
- avoid using left-hand and right-hand twistlocks on the same ship
- regularly examine lashing components, including ship fittings, for wear and defects. Replace worn or damaged lashing components. Repair worn or damaged ship fittings. Check all equipment, not just equipment in regular use. Keep turnbuckles and twistlocks clean and well greased
- consider additional lashings if bad weather is expected
- it is difficult to know when lashing components should be replaced. Few organisations are confident to issue 'criteria for replacement', which means that the ship's owner or individual master will need to exercise judgement. If in doubt, replace the equipment. Give special attention to dovetail or sliding socket foundations

■ remember that during ship rolling, forces on container corner posts can be up to three times greater than the upright compression force. Weather route in an attempt to avoid the worst of the meteorological systems or areas where high seas in winter are common. Check the specified limits of meta-centric height (GM) in the Cargo Securing Manual and make sure this is not exceeded. If navigating in bad weather, reduce speed, avoid beam seas and proceed with caution until the storm has passed

- try to avoid loading 'high cube' containers on deck in the first or second tier. Lashing rods are more difficult to fit and special rods with extension pieces are often needed. Before loading identify where these containers are to be stowed. It may be necessary to reposition them
- always consider personal safety when accessing lashing positions and working with lashing equipment. This applies equally in port and at sea

OUTBOARD CONTAINERS
WITH LASHINGS TO THE
BOTTOM OF SECOND AND
THIRD TIER BOXES



03 DO'S AND DON'TS

ALWAYS

- reject a container that is found to be overweight or is likely to give rise to the permissible stack limits being exceeded
- reject a buckled, twisted or damaged container
- check that containers have a valid CSC plate
- arrange stowage so that containers do not need to be unloaded at a port other than the designated discharge port
- regularly check lashing components for condition and discard components that appear worn or are damaged
- regularly check container corner castings for wear at the twistlock and lashing rod securing points. This is especially important when fully automatic twistlocks are used
- inspect D rings, ring bolts, cell guides and sliding socket foundations for wear or damage before containers are loaded, and arrange for the necessary repairs
- regularly check lashings during the voyage, when safe to do so
- inspect and tighten lashings before the onset of bad weather. Pay particular attention to forward and aft areas, and where vibration could cause turnbuckles to loosen
- take care when handling container fittings, as they are heavy. Avoid dropping them
- stow loose lashing components, twistlocks and lashing rods safely in designated baskets or racks
- buy components that are supported by a test certificate. The strength of equipment without a test certificate may be unpredictable. Keep a copy of the test certificate on board
- have more securing equipment than necessary
- avoid extreme values of GM, whether high or low
- avoid stowing 'high cube' containers in outboard positions
- avoid geographical areas where conditions for parametric rolling exist
- look for indications of water leakage into the container; look for indications of leakage from the container
- use safety equipment
- fit removable fencing before accessing lashing positions
- close gratings and covers after passing through
- report faulty equipment, including damaged ladders, fencing, lighting or safety rails
- report problematic work arrangements and discuss lashing safety during safety committee meetings. Feedback can help to make ships safer
- make sure container doors are closed

NEVER

- mix left-hand and right-hand twistlocks

- apply fully automatic twistlocks without first checking the manufacturer's instructions for use and the requirements in the ship's Cargo Securing Manual

- use corroded or buckled lashing rods

- use twistlocks that are not certified

- use improvised equipment to secure containers

- load containers of a non-standard length or width except when the ship is designed and equipped for the carriage of these non-standard containers

- overtighten lashing rods. This can occur when lashing rods are tightened during ship rolling, because one side of crossed lashings will be less tight on the heeled side. Tightening on a roll can cause over-tightening. Lashing rods can also be overtightened when a very long metal bar is used to tighten the turnbuckle

- use twistlocks for lifting containers except where the twistlocks are specifically approved for this purpose

- open containers after they have been loaded. Closed doors are a component of the container's strength

- connect reefer containers to damaged or broken electrical sockets

- load containers in a con-bulker that requires fitting a buttress, unless the buttress is already fitted

- lash to the top of a container; always lash to the bottom of the next tier wherever possible

- use a fully automatic twistlock to secure containers when the container's bottom is exposed and it could be lifted by green seas

- apply lashings to the overhanging end of a 45-foot container when the container is stowed over a 40-foot container. 45-foot containers are usually stowed aft of the ship's accommodation and above the position where lashing rods are applied. They are therefore held in position with twistlocks

- stand or walk below containers that are being lifted. Twistlocks or other debris can sometimes fall

- work dangerously with containers. Never stand or climb onto them, or under or between them

- drop or throw fittings, especially twistlocks, from a great height onto a steel deck or other hard surfaces

- use a mixture of fully automatic, semi-automatic and manual twistlocks in the same stowage

- remove the hatch cover stoppers before hatch cover stowed containers have been discharged

- stand adjacent to container stacks which are being loaded or unloaded. The container may swing and hit you

04 LASHING SYSTEMS

COMMON FALSE BELIEFS

P&I club investigations into container losses indicate that a loss often occurs because an apparent weakness has not been identified. The following common false beliefs or assumptions are worth noting:

■ **Once containers have been loaded and secured, the stow remains in a tight block and does not move**

Twistlock and sliding socket clearances will allow containers to move before the twistlocks engage. The clearance will permit movement of the stow. Wear inside the corner fitting can cause additional movement.

■ **Containers can be stowed in any order and/or combination/mix of weights**

The most common mistake made when stowing and lashing containers is to load heavy containers over light or to load so that the maximum permissible stack weights are exceeded. Heavy on light can only be accepted when specifically permitted in the Cargo Securing Manual.

■ **Lashings applied from a lashing bridge behave in the same manner as those applied at the base of a stow**

A lashing bridge is a fixed structure while a hatch cover will move when a ship rolls and pitches. The resulting effect could be that a lashing from a lashing bridge becomes slack or takes excessive load.

■ **Containers loaded on a pedestal and a hatch cover do not suffer additional loading**

A hatch cover is designed to move as the ship bends and flexes. A container stowed on a pedestal, a fixed point, will attempt to resist hatch cover movement if also secured to a hatch cover.

■ **Lashing rods should be tightened as tight as possible**

In theory, excessive tightening of lashing rods will result in the rods taking additional strain, which can cause rod failure when under load.

■ **Extra lashings will always make the stow safer**

Application of extra lashings can, at times, make the stow very rigid, causing large forces to pass to container-securing points and causing them to fracture.

■ **It is not necessary to adjust the tension in lashings while at sea**

Movement of containers will result in some lashing rods becoming slack. Air temperature differences will cause the tension in the lashings to change.

False

Lashings should be checked and tightened within 24 hours after leaving port and regularly thereafter. This is especially true before the onset of bad weather.

■ **Container strength is equal throughout the container**

Although strength standards are met, a container is more flexible at the door end and may be more vulnerable in this area.

■ **All twistlocks can be used to lift containers**

Twistlocks can be used for lifting containers only when they have been approved and certified for that purpose.

■ **Twistlocks are all rated to the same strength**

Twistlocks can be rated for different tensile loads up to 20 or 25 tonnes. It is important not to use a mix of twistlocks that have different strength ratings.

■ **All containers have the same strength**

Container strength can vary. There are two ISO standards (pre- and post-1990). Some owners have their own standards and containers can be worn or damaged.

■ **Horizontal lashings from lashing bridges are an alternative to vertical cross lashings**

Crossed horizontal lashings from lashing bridges will hold a container.

However, the container will be held rigidly to the fixed lashing bridge. When a ship bends and twists, the base of a container attached to a hatch cover will move, but container ends held firmly to a lashing bridge with horizontal lashings will not move. The effect will be to put strain on the lashings and even break the bars or damage the container corner castings. Horizontal lashings should not be used unless specifically permitted in the approved lashing plans shown in the Cargo Securing Manual.

■ **Parametric rolling will not occur on ships with a high GM**

Parametric rolling occurs because of the fine hull form of large post-Panamax container ships. The large bow flare and wide transom increase the effect. The phenomenon occurs because of changes in the waterplane area, which can cause large changes in GM as waves pass. At times, GM can become negative. A large initial GM will provide large righting levers that can lead to violent rolling.

■ **Provided stack weights have not been exceeded, the distribution of containers in a stack on deck is not important**

It is essential to avoid loading heavy containers over light, or at the top of a stack in a deck stow, unless specifically permitted in the Cargo Securing Manual. This is because the securing system would normally have been designed on the assumption that light containers are stowed on top. Stowage

False

may allow for 'heavy-heavy-light'; however, loading 'heavy-medium-medium' may result in the same stack weight but would produce different strain on the securing system, especially if the GM is high.

■ **Containers need not be stowed in block stowage**

Generally, container stacks do not depend on each other for support. However, they do provide protection to each other from wind and waves, so stowage in isolated stacks, especially in outboard locations, should be avoided.

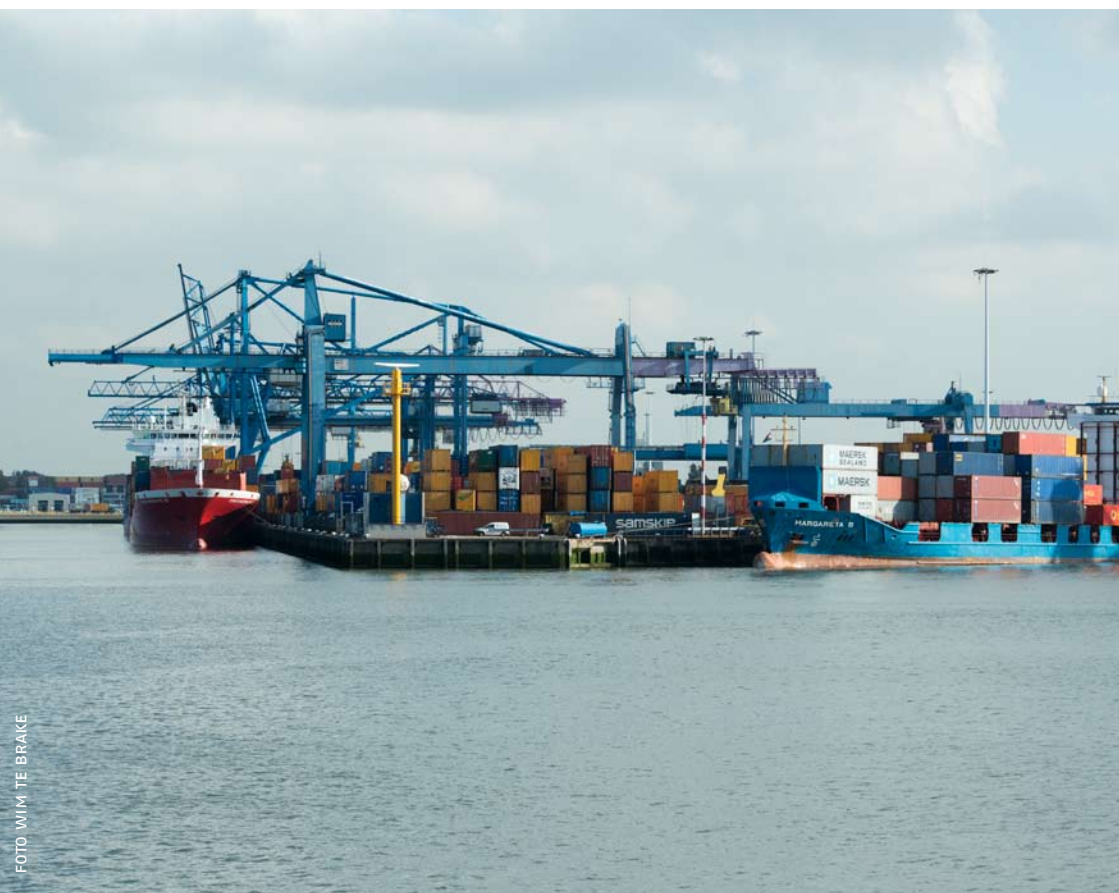

05 SAFE WORKING

WORKING WITH CONTAINERS

The decks, hatch covers, lashing bridges and holds of a container ship can be hazardous places to work. To avoid accidental injury, exercise care and follow these rules:

- when working on deck, always wear high visibility clothing, safety shoes and a hard hat
- always install temporary fencing and safety bars before starting cargo operations
- never allow fittings to be thrown onto the ship's deck from a height
- check that sliding sockets and stacking cones are removed from hatch covers before opening
- when working in the vicinity of moving containers, never work with your back towards a container or stand where a swinging container could strike you
- never stand or walk under a raised container
- never place your hand or clothing under a container that is being lowered
- when working on the top or side of a container, use safe access equipment and never climb containers
- if working from a portable ladder make sure the ladder is properly secured, has non-slip feet so that metal-to-metal contact is avoided. Wear a safety harness, a hard hat and high visibility clothing. Attach the line from the harness to a secure point and arrange for a member of the ship's crew to stand-by to assist
- take care climbing onto a lashing bridge. There could be loose items of equipment that can fall or the safety bar could be across the opening
- tidy loose equipment that is lying on decks, hatch covers, lashing bridges and coamings. These are trip hazards
- never climb up a stack of containers. Use an access cradle
- take care when fixing penguin hooks or lashing rods, as these can slip and strike someone
- avoid excessive stretching, bending or leaning when placing lashing rods. Their weight can be deceptive
- close access gratings after passing through. They are there to protect you

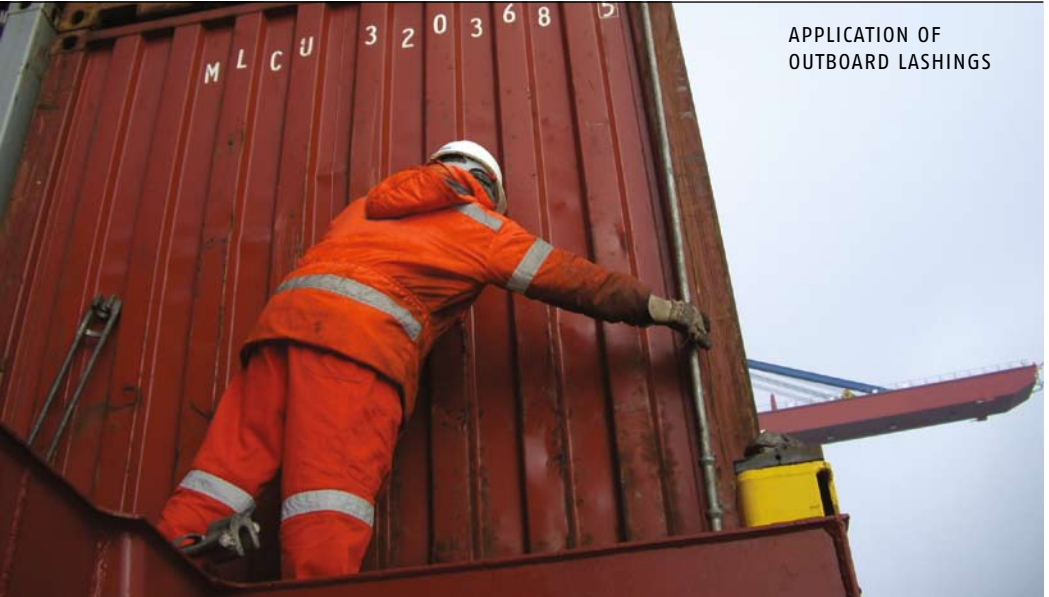
APPLICATION OF
OUTBOARD LASHINGS

LASHING AREAS

Ships should be arranged to enable safe application and inspection of container lashings. Work areas should be of adequate dimensions, free from trip hazards, provided with fall protection and with adequate lighting. Transit areas should be free from obstructions and trip hazards. They should have adequate headroom, lighting and non-slip walkways. The main working positions are between stacks, on lashing bridges, outboard and on hatch cover ends. A risk assessment of working positions should be arranged to identify hazards and to enable corrective action. When completing these assessments, the following requirements for safety during the application of lashings should be considered.

WORKING AREAS MUST:

- avoid the necessity for container top working or, where that is not possible, temporary fencing
- be designed with the work platform and lashing plate on the same level
- be of adequate size
- be arranged to avoid excessive stretching or bending during lashing application
- have outboard areas and potential falls fitted with permanent
- have adequate lighting and non-slip surfaces
- have safe arrangements for stowage of spare lashing equipment
- have access hatch openings to raised working areas closed by gratings rather than solid covers

Potential falls from heights of 2m or more need to be fitted with fall protection in the form of fencing. Fencing should have its top rail at least 1m high and an intermediate rail should be fitted at a height of 0.5m. Toe boards should be fitted where people below could be exposed to falling objects.

Work areas and walkways, whether above or below deck or on a lashing bridge, require lighting. In work areas, the level of lighting should be sufficient to enable the inspection of containers, both in port and at sea, to detect damage and leakage, and to read markings or labels.

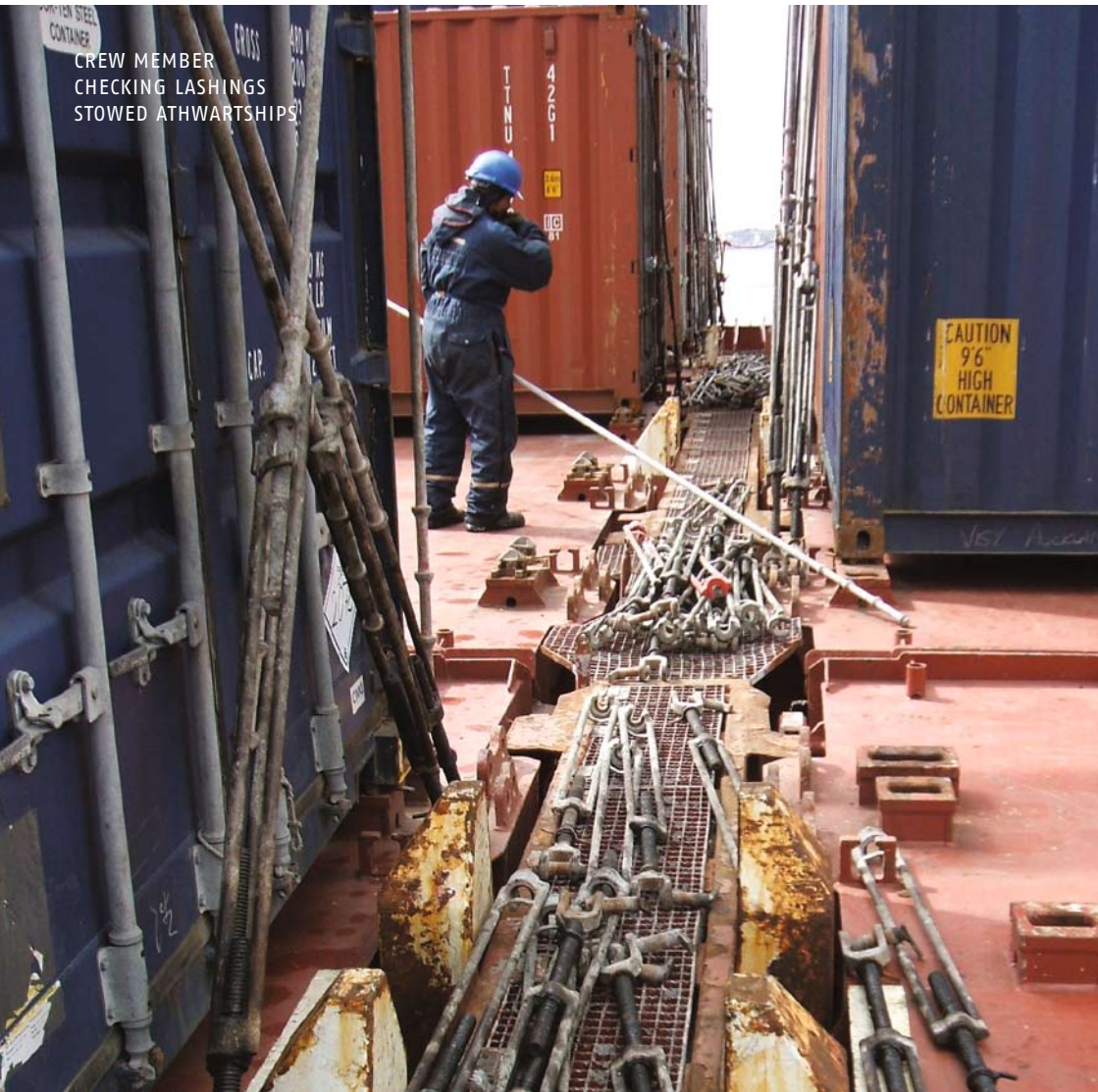

CREW MEMBER
CHECKING LASHINGS
STOWED ATHWARTSHIPS!

06 SHIPS



A ship is only designated as a container ship when it is designed exclusively for the carriage of containers. Other ship types that carry containers as part of a mixed cargo are often categorised as 'suitable for the carriage of containers in holds xxx and x'.

P&I clubs provide cover for the carriage of containers on deck only when the ship is specifically designed, fitted or adapted for the trade. This means that hatch covers and container landing points are approved for the particular stack weight and the lashing system satisfies classification society design criteria.

Containers can be carried on many ship types – cellular container ships, con-bulkers, bulk carriers and general cargo ships. The following is a brief description of the ships and their features.

SHIP TYPES

CELLULAR
CONTAINER SHIP



CONTAINER SHIPS

- designed exclusively for the carriage of containers
- containers in holds are secured by cell guides
- containers on deck are secured by portable lashing components, often rods and twistlocks

HATCHCOVERLESS
CONTAINER SHIP



CONTAINER SHIPS – HATCHCOVERLESS

- designed exclusively for the carriage of containers
- no hatch covers
- bridge may be located fully forward to provide protection
- if the bridge is not sited forward, it is common for the forward two or three holds to be fitted with hatch covers, especially if dangerous goods are to be carried
- all containers are secured in cell guides

TYPICAL ARRANGEMENT
FOR CON-BULKER WITH
GANTRY CRANE



CON-BULKERS

- a ship with hold arrangements suitable for the carriage of both containers and bulk cargoes
- various configurations, including:
 - bulk cargoes carried in designated holds, containers in other holds
 - containers carried above bulk cargo
 - containers carried only on deck

RO-RO CARGO SHIP WITH
CONTAINERS ON DECK



RO-RO SHIPS

- various configurations, including:
 - Ro-Ro cargo aft and containers in conventional holds forward
 - containers loaded by forklift trucks in Ro-Ro decks
 - containers on deck and Ro-Ro cargo in the Ro-Ro deck

MULTI-PURPOSE
GENERAL CARGO SHIP
WITH CAPACITY TO CARRY
CONTAINERS ON DECK

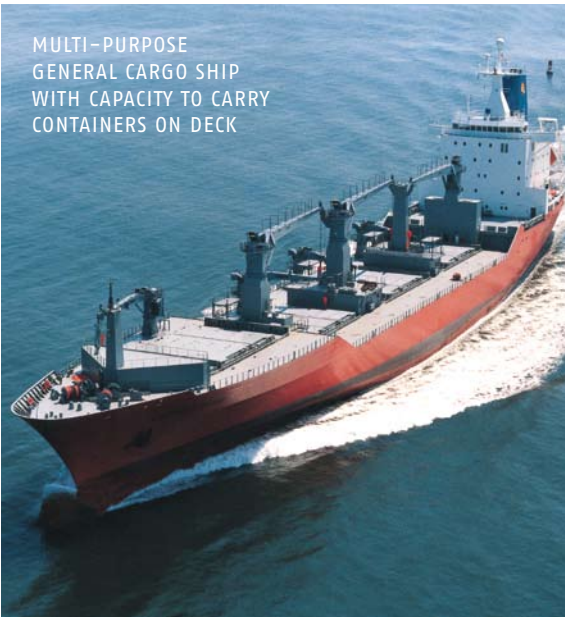

GENERAL CARGO SHIPS

- containers in holds, generally secured by buttresses and bridge fittings
- containers on deck secured by container securing equipment
- containers may be carried athwartships. Only possible when cargo is carefully stowed within the container
- containers loaded on dunnage and carried as general cargo

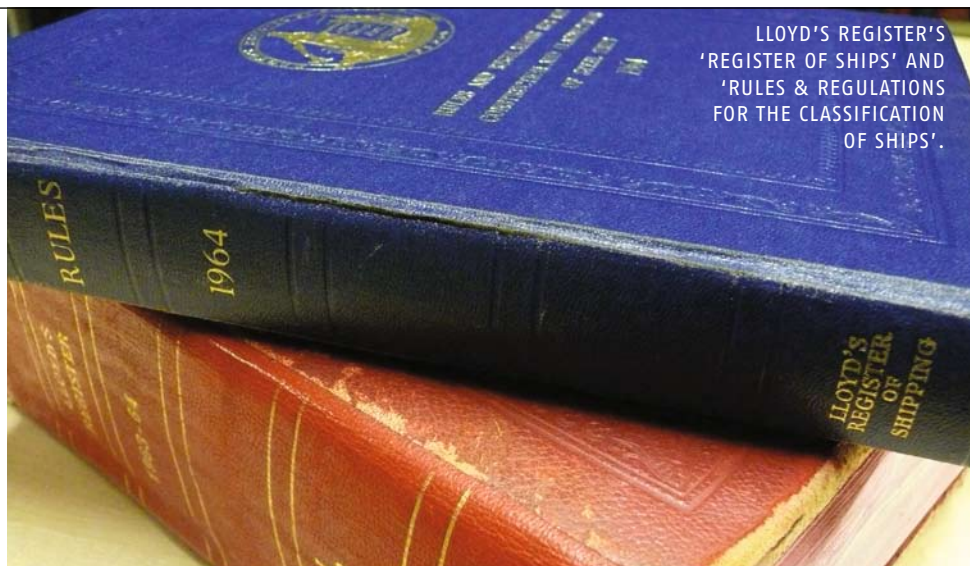

LLOYD'S REGISTER'S
'REGISTER OF SHIPS' AND
'RULES & REGULATIONS
FOR THE CLASSIFICATION
OF SHIPS'.

SHIP CLASSIFICATION

The ship classification process ensures that the ship's hull, hatch covers, lashing bridges, cell guides and fixed fittings have sufficient strength. Loose fittings such as container securing components may be excluded from this certification process. Although a classification society may assess the adequacy of loose fittings and assign a class notation, this examination is additional to the mandatory ship classification process.

P&I clubs require a ship to be approved for the carriage of containers by a classification society and for the container securing arrangements to at least meet that classification society's design requirements.

Multi-purpose ships may carry containers and general cargo. These ships can be cellular container ships with a stiffened tanktop with the ability to 'stopper' (block) cell guides.

Sometimes owners wish to carry bulk or general cargoes in container ships. A ship which is classed as a container ship will not have been assessed for this type of loading, nor will the inner bottom, hatch covers, loading manual, Cargo Securing Manual and ISM certification have been approved for the carriage of these cargoes. Before general cargo can safely be carried on a container ship certification as a general cargo ship is necessary. The club has published an edition of Standard Cargo on the subject of container ships and general cargo.



FOTO WIN TE BRAKE

07 CONTAINERS

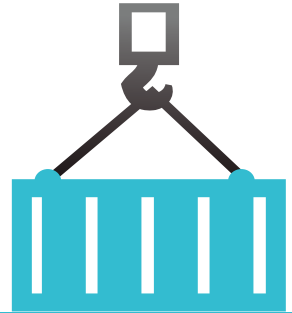

Most containers carried at sea are designed and approved to ISO standard and are regularly inspected in accordance with the International Convention for Safe Containers (CSC) for damage, to ensure that they continue to be suitable for the very large loads which they are required to bear while at sea. There are various types, sizes and designs of container. Not all are suitable to be part of a container stow.

CONTAINER SIZES

Containers are standardised cargo units. They are normally manufactured to the sizes specified in ISO 668, but they can be manufactured in a variety of sizes and types, each designed to meet specific cargo and transportation requirements. Their length is usually 20 or 40 feet, although longer containers are used, principally in the US trade; these containers are 45, 48 and 53 feet long. Their width is standardised at 8 feet (2,438mm), although their height can vary. The term ‘high cube’ container usually refers to a standard sized container that has a height of 9 feet 6 inches. Container heights can be 8 feet, 8 feet 6 inches or 9 feet 6 inches.

Containers are referred to by the acronym TEUs – 20 foot equivalent units, or 40 foot equivalent units (FEUs).

The ISO standard for containers (ISO 668) defines dimensions, both internal and external, and load ratings. All containers have a framework and corner posts fitted with corner castings. The castings at each corner of the container support the container’s weight.

The castings are the only points at which a container should be supported and are used to attach securing fittings, such as lashing rods and twistlocks. The position and spacing of corner castings are carefully controlled.

Containers with stacking limitations (such as 5-high stack) have labels clearly marking these requirements. The stacking capability is also specified on the CSC Plate.



The usual value for allowable stacking is 192,000 kg, which is a 9-high stack of containers, calculated as 8 containers stacked above, each with a mass of 24,000kg (8x24,000=192,000).

Containers that are longer than 40 feet usually have additional support points at the 40-foot position so that they can be stowed over a standard 40-foot container. Standard sizes for ISO Series 1 freight containers include those shown in the table below.

Twenty-foot containers are actually a little shorter than 20 feet, so that two 20-foot containers can be stowed in a 40-foot bay. The actual dimensions are 12,192mm for a 40-foot container and 6,058mm for a 20-foot container. Thus, two 20-foot containers are 76mm shorter than a 40-foot container. This clearance is often referred to as the ‘ISO gap’.



DO NOT LASH TO THE
OVERHANGING END OF A
45-FOOT CONTAINER

STANDARD SIZES FOR ISO SERIES 1 FREIGHT CONTAINERS

Designation	Length	Width	Height
(non-ISO)	45'	8'	9' 6" 8' 6"
1AAA			9' 6"
1AA	40'	8'	8' 6"
1A			8'
1AX			< 8'
1BBB			9' 6"
1BB	30'	8'	8' 6"
1B			8'
1BX			< 8'
1CC			8' 6"
1C	20'	8'	8'
1CX			< 8'
1D	10'	8'	8'
1DX			< 8'

APPROXIMATE DIMENSIONS, IN FEET AND INCHES. MOST COMMON SIZES HIGHLIGHTED. SUFFIX 'X' MEANS THE CONTAINER HEIGHT IS LESS THAN 8 FEET.

CONTAINER TYPES

There are a number of types of container in common use. They all have basically the same frame, and the differences relate to what they can be used for and access.

DRY VAN BOXES

- these are the most common type
- they have corrugated steel walls, timber base, steel or glass reinforced plastic (GRP) top
- corrugated walls can be made from plate from as little as 1.6mm (1/16 inch) in thickness
- their frame consists of side and end rails, and corner pillars fitted with corner castings
- the closed end is approximately 4.5 times more stiff, in racking strength, than the door end
- closed doors are a component of their strength



40-FOOT DRY VAN BOX CONTAINER

CURTAIN WALL CONTAINERS

- curtain wall containers are similar to dry van boxes, but have fabric side walls that can be opened to facilitate easy cargo handling



REEFER UNIT

REFRIGERATED CONTAINERS

- general construction as for dry van boxes
- they usually have their own refrigeration unit, with an air or water-cooled heat exchanger
- a small number of CONAIR boxes use close-coupled ventilation
- they have their own data logger to record temperature
- some have controlled atmosphere for the carriage of fruit



TYPICAL ARRANGEMENT FOR A TANK CONTAINER

TANK CONTAINERS

- steel skeletal framework within which the tank is housed
- steel framework must have equivalent strength to a dry van box
- the tank has its own design and strength criteria and it may be a pressure vessel
- if carrying 'dangerous goods' the tank container will also be certified to ADR/RID/IMDG

FLAT-RACK CONTAINERS

- the container frame can be folded flat for ease of transportation when empty
- the structure must have equivalent strength to a dry van box

EURO CONTAINERS

- Euro containers are 45-foot containers designed to comply with EU Directive 96/53
- they have shaped corner castings to comply with road transportation regulations
- their cell guides need to be appropriately designed to ensure that the containers cannot slip out of them



CORNER CASTING ARRANGEMENT FOR A EURO CONTAINER



TWO FLAT RACKS OVER STOWED

08 CONTAINER CONSTRUCTION

The strength of a container is provided principally by the outer framework, side rails and corner posts, together with the corner castings. The side, end panels and closed doors provide racking strength.

CORNER POSTS

Effective stacking of containers relies on the strength of the corner posts to support the weight of the containers above. Damage to a corner post, in particular buckling, can seriously degrade its compressive strength and lead to the collapse of a container stack.

A series of tests is undertaken on a prototype container to comply with the Lloyd's Register Container Certification Scheme, the CSC and the applicable ISO standards.

These tests simulate the different loads the container is likely to be subjected to; an example of this in the photo above is a stacking test.

THE OUTER FRAME

Horizontal forces on the container, such as those caused by roll and pitch motions, are resisted by the racking strength of the container. This is

provided by the frame and also by the plate walls. Of course, soft-walled containers rely totally on the racking strength of the frame.

CORNER CASTINGS

A container's corner castings take the twistlocks or stacking cones, which are used to connect containers to each other or to the ship's deck/hold, and the lashing rods, which are used to secure and support the stow. During lifting, the crane's spreader bar connects to the corner castings.

While compressive loads can be carried by the direct contact between the containers, tensile and shear loads are resisted by the loose fittings. It is important that the corner castings are in good condition if the fittings are to work effectively and perform their intended function.

The position of corner fittings must be carefully controlled during the



CONTAINER TEST RIG

manufacture of containers to ensure that they fit together properly and to ensure that the fittings work effectively.

FORKLIFT POCKETS

These can be cut into the bottom side rail and are used when the containers are lifted by a forklift truck. Forklift pockets are a discontinuity in the side rail that could weaken the container if contact damage occurs.

CONTAINER CERTIFICATION

New designs of container are prototype tested to ensure that they have sufficient strength.

If tests prove satisfactory, then the container design may be certified by a classification society.

It is important to note that a container that has suffered damage to a corner casting or corner post will not be serviceable because:

- a damaged container may be unable to bear the weight of those stowed above
- a damaged container may render lashings ineffective
- lifting a damaged container is hazardous

If one container in a stack fails, it is likely that the entire stack will collapse.

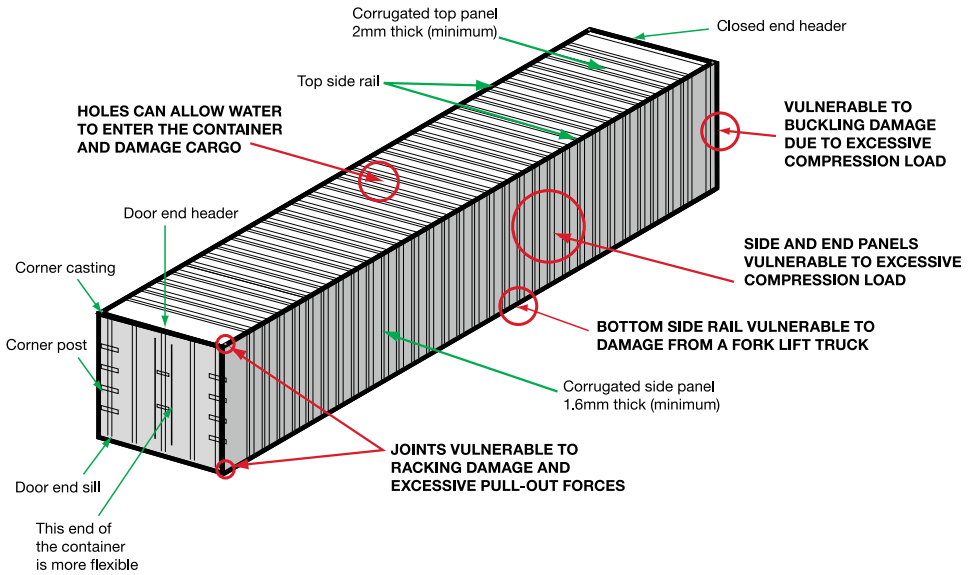

CONTAINER CONSTRUCTION AND FAULTS

CERTIFICATION

Certification is then issued by the classification society for containers of similar design, that are constructed by production methods and quality control procedures that are agreed and verified by survey. Changes in the method of construction may nullify the certification, unless the changes are approved by the classification society.

The Lloyd’s Register Container Certification Scheme (LR-CCS) covers three general categories of container:

- ISO Series 1 containers – all types, including: dry van boxes, reefer

containers, open top containers, non-pressurised dry bulk containers and platform-based containers

- Tank containers
- Offshore containers

The scheme ensures that each container complies with the appropriate ISO standard and applicable regulations, covering for example:

- dimensions
- strength of walls, floor and roof
- strength of corner posts
- rigidity (longitudinal and transverse)
- weathertightness
- number of other features as appropriate to the type of container, such as strength of forklift pockets

A container that has satisfactorily passed the Lloyd's Register Container Certification Scheme will bear the Lloyd's Register logo.



When containers are strength tested, it is important to remember that they are not tested for vertical tandem lifting and that the corner posts are only tested for compressive strength. In addition, it is only the top corner fittings that are tested for lifting; the bottom fittings are never tested. Twistlocks may be approved for vertical tandem lifting; however, such lifting is dangerous and should only be contemplated when a container's bottom corner castings are also approved for lifting. If in doubt, consult the ship's P&I club.

ISO SERIES 1 – FREIGHT CONTAINERS

The primary documents for the design of ISO Series 1 Freight Containers are:

- ISO 668: Classification Dimensions and Ratings

- ISO 1161: Corner Fittings, Specification

- ISO 1496-1: Specification and Testing. Part 1: General Cargo Containers for General Purposes

- ISO 1496-2: Specification and Testing. Part 2: Thermal Containers

- ISO 1496-3: Specification and Testing. Part 3: Tank Containers for Liquids, Gases and Pressurised Dry Bulk

INTERNATIONAL CONVENTION FOR SAFE CONTAINERS (CSC)

The CSC Convention sets out the standards for freight container construction and use.

The convention contains regulations on construction, inspection, approval and certification.

This includes design approval, witness of container manufacture and prototype testing and issuance of a safety plate. The CSC approval or safety plate contains information on the container's date of manufacture, the manufacturer's identification number, the gross operating weight, the allowable stacking weight and the transverse racking load. The plate may also have the end and/or side-wall strength value. The plate is issued when the container is manufactured.

In accordance with the CSC all containers shall be examined at intervals specified in the convention by one of two ways: either by a 'Periodic Exami-

nation Scheme' or under an 'Approved Continuous Examination Programme' (ACEP). Both procedures are intended to ensure that the containers are maintained to the required level of safety. The maximum period between examinations is set at 30 months or if there is a major repair or modification and for the ACEP scheme for on hire/off hire interchanges. For tank containers the ADR (Transport of Dangerous Goods by Road), RID (Transport of Dangerous Goods by Rail) and IMDG (Transport of Dangerous goods by Sea) also have in-service inspection requirements.

The standard EN 12972 thoroughly details these requirements.

CERTIFICATION OF REEFER CONTAINERS

The ability of a reefer container to maintain a given temperature when using its integral refrigeration unit is tested in accordance with ISO 1496-2. This consists of two tests: one to determine the heat loss through the envelope of the container and the other to ensure the refrigeration unit can operate with a specific internal load. These tests are arranged during type approval. The amount of electrical power required to maintain a reefer container at a given temperature depends on the size of the container (TEU or FEU), the required cargo temperature, the cargo being carried and the external ambient air temperature.

For example, 9 kW of electrical power is needed to maintain a temperature of minus 18°C in a 40-foot container carrying frozen meat, while a container carrying fruit at 2°C requires approximately 11 kW. This is because fruit respire and produce heat during transit.

Certain cargoes, for example bananas, may require even more power because of the greater heat produced as they ripen. There is a high electrical load on the ship's generators when reefer containers are carried.





CONTAINERS WITH OPEN DOORS

Some containers are certified for use with one or both doors open, or removed. This may be necessary to ventilate cargo. A note saying the container's doors can be open will appear on the CSC plate under the transverse racking entry. Unless a container is certified to have its doors open, the doors must be closed and secured – they are an integral part of a container's strength.

09 LASHING COMPONENTS

A variety of lashing components are available to secure containers, the majority of which are listed below. The table shows the locations where these components are commonly used.

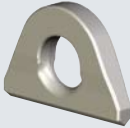
FIXED FITTING (ATTACHED TO SHIP)

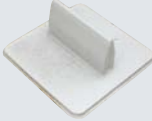

Description	Purpose	Image	Notes
Flush socket	Locating base twistlocks or stacking cones in the cargo hold.		Normally fitted over a small recess to ensure watertightness. Clean and remove debris before use.
Raised socket	Locating base twistlocks or stacking cones on deck.		Clean and remove debris before use.
Lashing plate or 'Pad-eye'	Tie-down point for turnbuckle.		Designed only for in-plane loading. An out-of-plane (out-of-line) load could bend the plate and may crack the connecting weld.
D ring	Alternative tie-down point for a turnbuckle.		Corrosion of the pin ends can weaken a D ring. Suitable for in-plane (in-line) and out-of-plane loading.
Dovetail foundation	Base for sliding dovetail twistlock.		Clean before use. Keep well greased and examine regularly for damage or wear.





Description	Purpose	Image	Notes
Fixed stacking cone	Locating base twistlocks or stacking cones in the cargo hold.		Often found at the base of a cell guide.
Mid-bay guide	To prevent transverse movement of 20-foot containers in 40-foot guides. Fitted at tanktop level.		Does not interfere with general stowage of 40-foot containers.

Loose fittings are those that are not permanently attached to the ship. Loose fittings must be certified by class or an appropriate recognised authority. However, they are not normally surveyed by the class society

surveyor during regular ship surveys. When using loose fittings, it is essential that the manufacturer's instructions are followed at all times, especially when using fully automatic and semi-automatic twistlocks.

LOOSE FITTINGS IN COMMON USE

Description	Purpose	Image	Notes
Lashing rod	To provide support for container stacks on deck. Used in conjunction with a turnbuckle.		Resists tensile loads. Very long lashing rods can be difficult to handle and difficult to locate in a container corner casting. They can have eyes at each end.
Extension piece	To extend a lashing rod when securing 'high cube' containers.		Fit at the base of all lashing rod and connect to the turnbuckle.
Turn buckle (bottle screw)	To connect a lashing rod to a lashing plate or D ring. Tightening puts tension into a lashing rod.		Resists tensile loads and is used to keep the lashing tight. Regularly grease its threads. Ensure the locking nut or tab is locked.

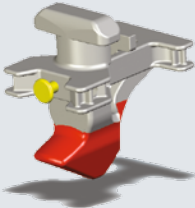

Description	Purpose	Image	Notes
Hanging stacker	Used in holds when 20-foot containers are carried in 40-foot guides. Locks into corner casting above.		Resists horizontal forces. Likely to be put in place when container is on shore because of difficulty in fitting when on board.
Semi-automatic twistlock (SAT)	Placed between containers in a stack. Locks into corner castings above and below.		Resists horizontal and separation forces. Can be fitted on shore. Automatically locks into the lower container when placed on top. It is easier to determine whether it is locked or not when compared to manual twistlocks. Unlocked manually.
Twistlock	Placed between containers in a stack. Locks into corner castings above and below.		Resists horizontal and separation forces. Each fitting requires locking after fitting. Left and right-hand types exist, causing uncertainty whether a fitting is locked or open.
Stacking cone	Placed between containers in a stack. Slots into corner castings.		Resists horizontal forces. Many types exist. May be locked into bottom corner castings prior to lifting a container on board.
Fully automatic twistlock (FAT)	Placed between containers in a stack. Locks into container casting above; hooks into container casting below.		A new and innovative design. Automatic unlocking during lifting. Usually opened by a vertical lift, with a twist/tilt. Should not be used if container corner castings are worn or damaged.





Description	Purpose	Image	Notes
Mid-lock	Placed between containers in a stack. Locks into corner castings above and below. Used on deck between 20-foot containers in 40-foot bays, at mid-bay position.		Resists horizontal and separation forces. Fitted to underside of container on shore and automatically locks into lower container when placed onboard. Consult the manufacturer's instruction manual for information on the lock's correct direction of fitting.

LOOSE FITTINGS IN LESS COMMON USE

These fittings are not commonly used but may be encountered occasionally. Fitting a bridge piece requires access

to the container top, something that should be avoided unless absolutely necessary.

Description	Purpose	Image	Notes
Sliding dovetail twistlock	To connect bottom containers to the ship.		Fits into a dovetail foundation. Used on hatch covers and in holds where a raised socket could cause an obstruction.
Bridge fitting	To link together the top containers of two adjacent stacks. Can be used on deck or in a hold.		Resists tensile and compressive forces. Potential drop hazard for stevedores/crew during placement.
Buttress	External support for container stacks in a hold.		Can resist compressive and tensile forces. Must be used in conjunction with higher-strength double stacking cones or link plates and aligned with side support structure.

Description	Purpose	Image	Notes
Double stacking cone	To link adjacent stacks, particularly those in line with buttresses.		Resists horizontal forces. More commonly used on con-bulkers below deck.
Load equalising device	To balance the load between two paired lashings.		Enables two parallel lashing rods to be connected to a single turnbuckle. Only use with designated lashing rods.
Penguin hook	Used as a supporting device in conjunction with a special lashing rod with an eye-end.		Likely to be put in place when container is on shore because of difficulty in fitting when on board. Risk of injury if it falls out when container is lifted onboard.
Elongated socket	Locating base twistlocks or stacking cones on deck.		Enables movement between a hatch cover and container to be taken up.



10 PRINCIPLES OF STOWAGE

Containers are rectangular box-shaped units of cargo. It is easy to stow them in classical block stowage both on and below deck.

When containers are carried on deck, the ship is required to be approved for that purpose and the containers themselves are secured with twistlocks and lashings. These usually consist of steel rods and turnbuckles.

When containers are carried below deck, the containers are slotted into cell guides on a cellular container ship, or sit on the tanktop, joined together with stacking cones, in the holds of a dry cargo ship. Containers can easily be stowed in box-shaped holds; it is more difficult to carry them in the holds of a dry cargo ship fitted with side hopper tanks, in which case, buttresses may be fitted.

When carried within a cell guide framework, no further external support is generally required. When 20-foot containers are stowed below deck in 40-foot cell guides, it may be beneficial to overstow the 20-foot containers with a 40-foot container. The Cargo Securing Manual should be consulted before loading.

Containers carried on deck may be secured by twistlocks alone, provided the stack is not more than two containers high. When containers are carried three high, twistlocks alone may be sufficient depending on the weight of the containers.

Horizontal movement of a deck stow is resisted by the twistlocks or cones. Lifting of containers in extreme seas is prevented by the pull-out strength of the twistlocks. The limitation of a twistlockonly stow is often the racking strength of the containers. For stows of more than three containers high, lashing rods are fitted because they provide additional racking strength.

In the early days of containerisation, lashings were fitted vertically to resist tipping. However, it soon became clear that it is more effective to arrange the lashings diagonally, so that the container and the lashings work together to resist racking.

The usual arrangement is to fit one tier of lashings, placed diagonally within

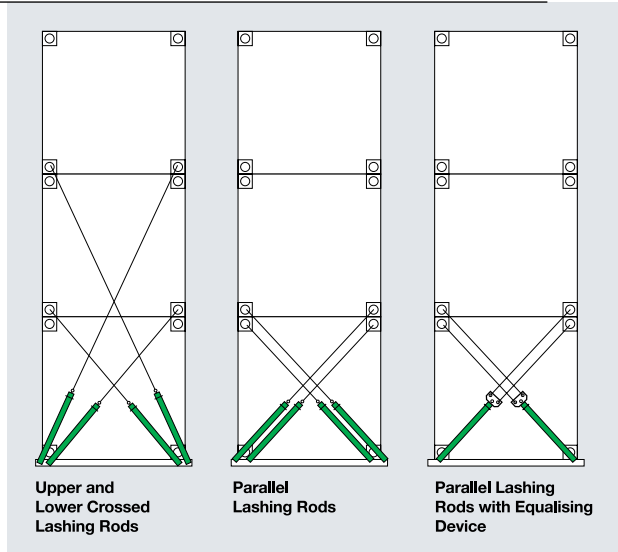

SECURING WITH PARALLEL LASHING RODS AND SEMI-AUTOMATIC TWISTLOCK

the width of the container, with the tops of the lashing rods placed in the bottom corner castings of the second-tier containers. This is called 'cross-lashing'. An alternative arrangement, with the lashing rods located outside of the width of the container, is called 'external lashing'. This is often used for high stacks which are lashed from a two-tier lashing bridge.

To enable the fitting of twistlocks, a twistlock is designed with a vertical and horizontal gap between it and a container's corner casting. This becomes important when considering how lashings behave during ship roll, pitch and heave. Lashing rods are always fitted tight and kept tight by adjusting the turnbuckle. When force is transmitted to securing equipment during

ship rolling, it is the lashing rods that bear the force first. It is only after the stack of containers has deflected and the gap at the twistlock has been 'taken up' that twistlocks become tight. For this reason, it is important to only use lashing rods that are in good condition and to apply them correctly. A second set of lashings may be fitted, connected to the bottom of the third tier of containers, as shown in the diagram.

If additional lashing strength is required, parallel lashings (parallel lashings) may be used. With this arrangement, lashings are arranged in parallel, one fitted to the top of the first tier and one to the bottom of the second tier. Tests have revealed that many containers are not

able to bear large downward loads on the upper castings, as can occur with para-lashings. This is particularly the case at the door end where the upper casting frequently overhangs the door and consequently has little support. The effectiveness of parallel lashings is taken as the lesser of 1.5 times that of a single lashing or the strength of the corner casting.

For ease of loading and discharge, bridge fittings that link adjacent stacks of containers together are not commonly fitted. However, since the force distribution and the response of adjacent container stacks will be similar, there is, in general, negligible load transfer between the stacks when linked together.

Bridge fittings tend to be used only on isolated adjacent stacks of containers in the holds of a dry cargo ship.

The ship's approved Cargo Securing Manual contains information on how to stow and secure containers, and on any strength or stack weight limitations.

The most common mistakes made are to exceed the permissible stack weight, to incorrectly apply lashings and to place heavy containers near the top of a stow.

CONTAINERS CARRIED BELOW DECK IN CELL GUIDES

The cargo holds of most container ships are designed for the carriage of 40-foot containers, with the containers held in place by cell guides. The cell guides are generally steel angle bars orientated vertically, with entry guides at the top to assist with locating the container – the clearances, and hence construction tolerances, are very tight.

The cell guides provide adequate longitudinal and transverse support to the 40-foot containers and no further securing arrangements are necessary. The lowest container in each stack sits on a pad, which is supported by the stiffened structure below the tanktop.

Twenty-foot containers may be stowed in 40-foot bays. This arrangement, referred to as mixed stow, requires longitudinal and transverse support for the containers where they meet at the mid-length position. This is achieved by mid-bay guides at the tanktop, placing hanging stackers between tiers of containers and possibly over-stowing two 20-foot containers with one or more 40-foot containers. Isolated stacks should be avoided.

In general, four hanging stackers should be fitted below each container, unless the Cargo Securing Manual specifically permits a lesser number.

Before loading containers in cell guides, it is important to make sure that the guides are not bent or deformed.

TYPICAL ARRANGEMENTS FOR CONTAINERS STOWED BELOW DECK

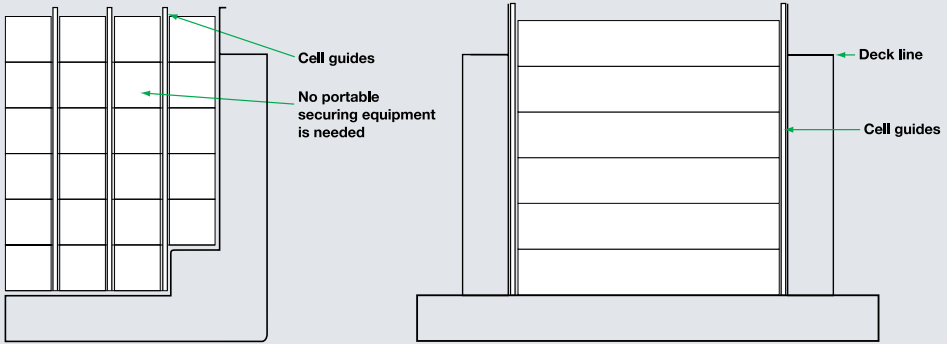

40-FOOT CONTAINERS IN 40-FOOT CELL GUIDES

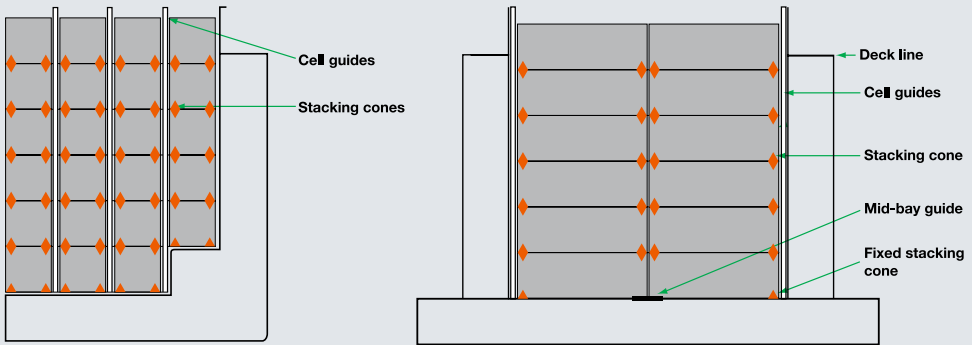

20-FOOT CONTAINERS IN 40-FOOT CELL GUIDES

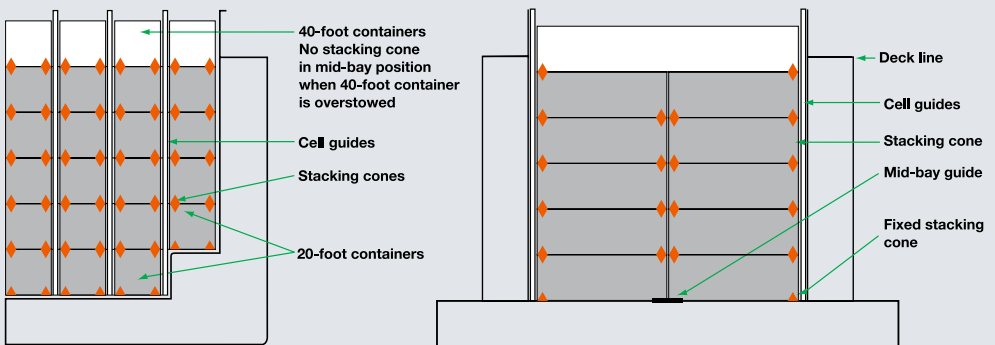

20-FOOT CONTAINERS IN 40-FOOT CELL GUIDES WITH 40-FOOT CONTAINERS STOWED ABOVE

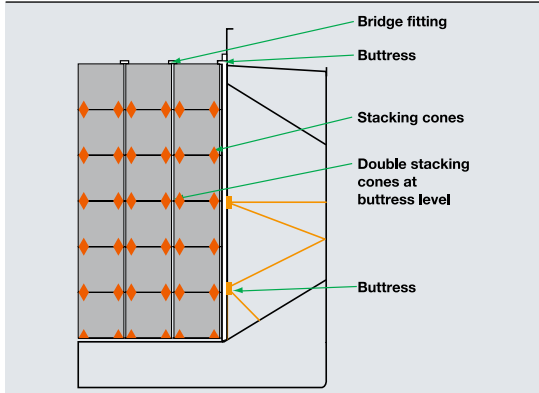

TYPICAL BULK CARRIER STOWAGE ARRANGEMENT WITH BUTTRESSES, USING SINGLE/DOUBLE STACKING CONES AND BRIDGE FITTINGS

CONTAINERS CARRIED BELOW DECK WITHOUT CELL GUIDES

Containers are generally stowed in the fore and aft direction, with the containers secured using locking devices only or by a combination of locking devices, buttresses, shores or lashings. The aim is to restrain the containers at their corners. Twistlocks are very good at preventing corner separation.

When carrying containers in the hold of a bulk carrier or general cargo ship, base containers are secured with twistlocks or cones. Buttresses should be fitted to provide lateral support. A platform, with sockets for cones or twistlocks, may be fitted in the forward and aft holds. This forms the basis for block stowage of containers when combined with cones, twistlocks and bridge fittings.

Various designs of portable buttress are available.

Aim for a tight block when loading containers below deck on a con-bulker. During loading, check to make sure that means are applied to ensure that the lowest tier does not slide when the ship rolls.

CONTAINERS CARRIED ON DECK

Containers are usually stowed longitudinally in vertical stacks.

Containers within each stack are fastened together with twistlocks. The bottom corners of each base container are locked to the deck, hatch cover or pedestal with a twistlock. When stacked in multiple tiers, the containers are usually lashed to the ship's structure by diagonal lashing rods.

The lashing rods are usually applied to the bottom corners of second or third tier containers. On ships fitted with lashing bridges, the lashing rods may be applied to the bottom corners of fourth or fifth-tier containers.

Lashings are applied so that each container stack is secured independently. In theory, the loss of one stack should not affect its neighbours.

Transverse stowage, although possible, is uncommon, mainly because cargo could move or fall out of the container when the ship rolls, but also because

transverse stowage requires rotation of the spreader bar of the shore gantry crane.

In some cases, containers are carried on deck in cell guides, in which case, the principles on page 33 apply. The same principles also apply to hatch-coverless container ships.

Containers carried at the sides of the ship are subject to wind loading. Consequently, it is common for 'wind lashings' to be fitted. These may be vertical or diagonal. It may also be necessary to fit wind lashings inboard if there are vacant stacks.

TYPICAL ARRANGEMENTS FOR CONTAINERS STOWED ON DECK

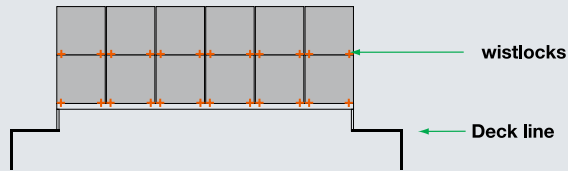

CONTAINERS SECURED BY TWISTLOCKS. USUALLY FOR TWO TIERS ONLY

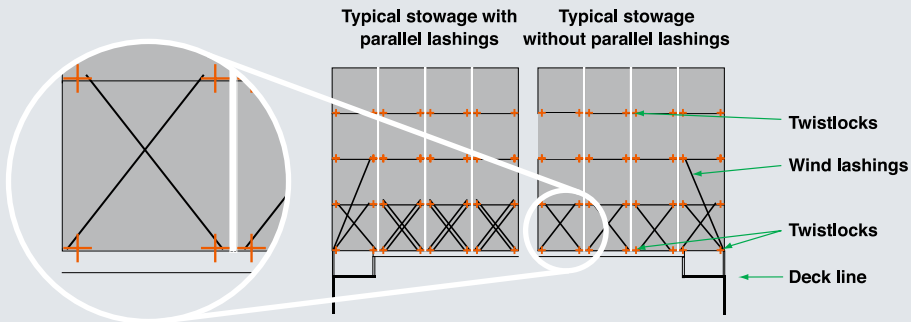

CONTAINERS SECURED BY TWISTLOCKS AND LASHING RODS. LASHING RODS TO BOTTOM OF SECOND TIER. WIND LASHINGS TO BOTTOM OF THIRD TIER

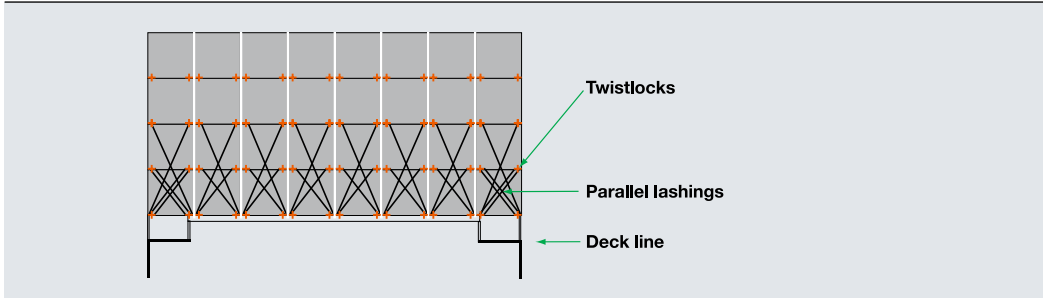

CONTAINERS SECURED BY TWISTLOCKS AND LASHING RODS. LASHING RODS TO BOTTOM OF THIRD TIER

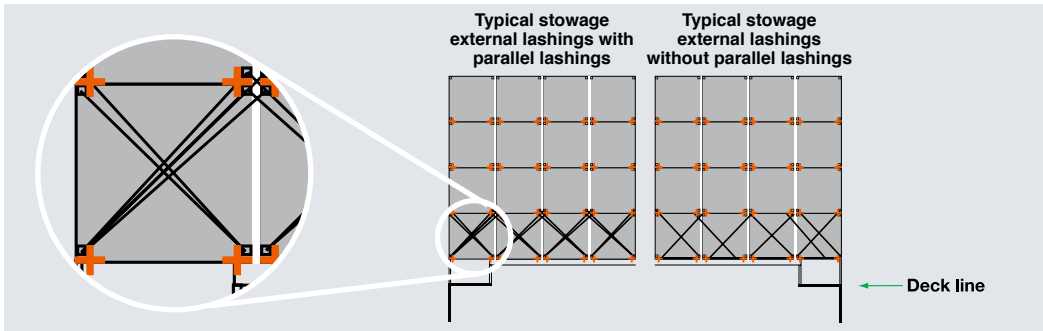

CONTAINERS SECURED BY TWISTLOCKS AND LASHING RODS, 'EXTERNAL LASHING' ARRANGEMENT

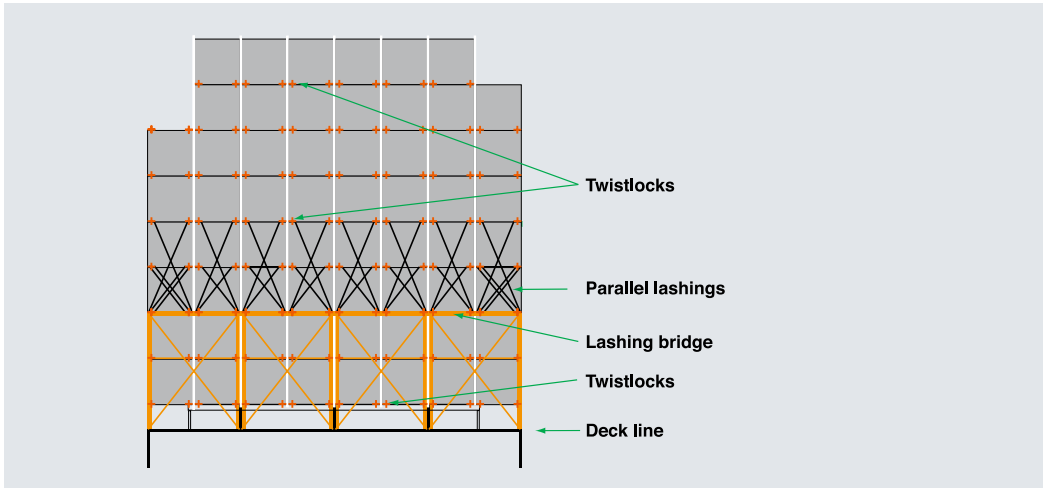

AS ABOVE BUT LASHINGS ORIGINATE FROM A LASHING BRIDGE. LASHING RODS TO BOTTOM OF FIFTH TIER

WHEN STOWING AND SECURING CONTAINERS, THE FOLLOWING POINTS SHOULD BE BORNE IN MIND:

- a deck stack of containers is only as strong as the weakest component in that stack. Premature failure of a component can cause loss of an entire stack. During loading, containers should be inspected for damage and, if damaged, they should be rejected
- twistlocks limit vertical and transverse movement. Diagonal crossed lashing rods, placed at the ends of a container, can withstand large tensile loads
- outside lashings are sometimes used. These are lashings that lead away from a container. However, although this arrangement provides a more rigid stow than a combination of crossed lashings and twistlocks, it is less common
- containers exposed to wind loading need additional or stronger lashings. When carried in block stowage, it is the outer stacks that are exposed to wind loading. However, when carried on a partially loaded deck, isolated stacks and inboard containers can also be exposed to wind, in which case, additional lashings need to be applied
- if containers of non-standard length, that is, 45, 48 or 53 feet are carried, the ship arrangement will need to be specially adapted
- 45-foot containers fitted with additional corner posts at 40-foot spacing can be stowed on top of 40-foot containers. Lashings can be applied in the normal way. It should be noted, however, that the additional corner posts may not be suitable for carrying the required loads, either from the container itself or from those stowed above. Lashings should not be applied to the overhang. The container specification and the Cargo Securing Manual should be consulted
- 40-foot containers may be stowed on top of 45-foot containers. However, this arrangement of stowage will present difficulties in fastening/unfastening twistlocks, and it will not be possible to apply lashings to the 40-foot containers
- when carrying over-width containers, for example 45-foot or 53-foot containers with width 8'-6", adaptor platforms may be used. These must be certified by a class society or an appropriate recognised body. The arrangement must be defined and approved in the ship's Cargo Securing Manual
- twistlocks should always be locked, even when the ship is at anchor, except during container loading and unloading. Lashing rods should be kept taut and, where possible, have even tension. Lashing rods should never be loose nor should they be overtightened. Turnbuckle locking nuts should be fully tightened

■ as a ship rolls, pitches and heaves in a seaway, tension, compression and racking forces are transmitted through the container frames, lashings and twistlocks to the ship's structure. However, clearances between securing components and the elasticity of the container frame and lashing equipment produce a securing system that forms a flexible structure. Thus, a deck stow of containers will move

■ containers can be held by only twistlocks when two or three tiers are carried on deck, depending upon container weights

■ arrangements with automatic and semi-automatic twistlocks are used to reduce time spent securing the stow and to eliminate the need for lashers to climb the stacks

CHECKS AND TESTS DURING DISCHARGE AND LOADING

■ regularly examine lashing components, looking for wear and tear, damage or distortion. Check that left-hand and right-hand locking twistlocks are not being mixed in the same storage bin. Remove from the ship any lashing component found to be worn, damaged or distorted

■ make arrangements for some damaged or distorted lashing components to be sent for non-destructive testing. This will determine their strength and help to establish replacement criteria

■ carefully check twistlocks that stevedores return to the ship as the locks might not originate from your ship, that is, their strength and locking direction could differ

■ discourage stevedores from treating lashing equipment roughly as this can induce weakness

■ examine dovetail foundations, D rings and pad-eyes for damage. Repair if damage is found

■ observe the loading of containers to determine if stowage is in accordance with the stowage plan and that best practice is always followed

■ observe the application of lashings to make sure that they are correctly applied in accordance with the requirements set out in the Cargo Securing Manual



TRANSPORT OF 40-FOOT CONTAINERS

CHECKS AND TESTS AT SEA

- 24 hours after sailing, examine, check and tighten turnbuckles. Check that lashings are applied in accordance with the Cargo Securing Manual and that twistlocks have been locked
- examine lashings daily. Check that they have not become loose and tighten turnbuckles as necessary
- before the onset of bad weather, examine lashings thoroughly and tighten turnbuckles, being careful to keep an equal tension in individual lashing rods. If necessary, apply additional lashing rods to the outboard stacks and to stacks with 20-foot containers in 40-foot bays
- re-check lashings after passing through bad weather
- make sure that lashing equipment that is not in use is correctly stored in baskets or racks
- make an inventory of lashing equipment and order spares before they are needed
- check that refrigerated boxes remain connected to the ship's power supply

11 SHIP'S BEHAVIOUR

Container ships, due to the nature of their trade, are required to keep to very tight operating schedules. Maintaining the schedule is an important part of the liner trade. As a result, these ships have powerful engines, not only to provide the high speeds required, but also to enable speed to be maintained during bad weather.

The consequence is that, at times, container ships can be driven hard. When ships are driven hard in bad weather, the loads on the lashings can be severe.

There are many load components arising from a ship's motion. These are discussed below.

SHIPS' STRUCTURE

The combined weight of a stack of containers may amount to a total downward force on the tanktop, through each container corner casting, of up to 100 tonnes. When four container corners are placed close together, such as at the mid-hold position when carrying 20-foot containers, the total local load on the tanktop may be four times this load.

During classification, the strength of the ship's structure to support containers is verified and approved. This includes assessment of the

strength of the tanktop, the cell guides and, on deck, the strength of the hatch covers, lashing bridges, pedestals and the fixed fittings associated with the container stow.

It is important to carry containers within the loading conditions imposed by the classification society. Container loads should never exceed the limits set down in the ship's loading manual.

CONTAINER STRENGTH AND SHIP MOTION

Although a ship has six degrees of motion, it is roll, pitch and heave which produce the most significant contributions to the forces on a container stow. Surge is important for road and rail transportation and containers are designed with this in mind.

The motion of a ship in irregular seas is itself irregular and is impossible to accurately predict. Consequently, when calculating accelerations on a stack

of containers, regular cyclic response is assumed in association with an assumed maximum amplitude. Empirical formulae for maximum amplitude and period of response are defined in the Rules and Regulations for the Classification of Ships by Lloyd's Register. Rolling motion is dominant in the calculation of forces, but rolling must be considered in association with the other components of the ship's motion to establish the largest likely combination of forces which the stow may experience.

For calculation purposes, the forces acting on a container may be resolved into components acting both parallel to, and perpendicular to, the vertical axis of the container stack. Gravity acts vertically downwards and, therefore, when the stack is inclined at maximum roll or pitch, there are force components of static weight acting both parallel to, and with, the vertical axis of the stack. The dynamic components of force are vectors. These are combined algebraically with the static components.

Wind is assumed to act athwartships and to affect only the exposed stacks on the windward side of the ship. The magnitude of wind force, for a wind speed of 78 knots, is about 2 tonnes on the side of a 20-foot container and about 4 tonnes on a 40-foot. The vertical component of wind on the top of the uppermost inclined container is ignored.

The assessment of the effect of green seas on exposed container stacks is by necessity empirical. The general principle is to require the container securing arrangement in the forward quarter of the ship to be suitable for forces increased by 20%, except when the ship has an effective breakwater or similar.

Calculations of forces acting on a container consider various combinations of the individual components of motion. Within each combination it is necessary to define the instantaneous positions in the cycle of motion at which the calculations are made.

Of course, in an actual seaway, all components of motion act simultaneously to a greater or lesser extent.

LLOYD'S REGISTER RULES ALLOWABLE FORCES ON AN ISO CONTAINER (ISO 1496-1:1990)

The calculation of the forces in the lashing arrangements is clearly a very complex matter.

This is further exacerbated by the deflections of the hull. For example:

- the cross-deck structure may move by as much as 50mm as the containers surge forward and aft
- as the ship makes its way through a head or stern quartering sea, the hull twists, distorting the hatch openings

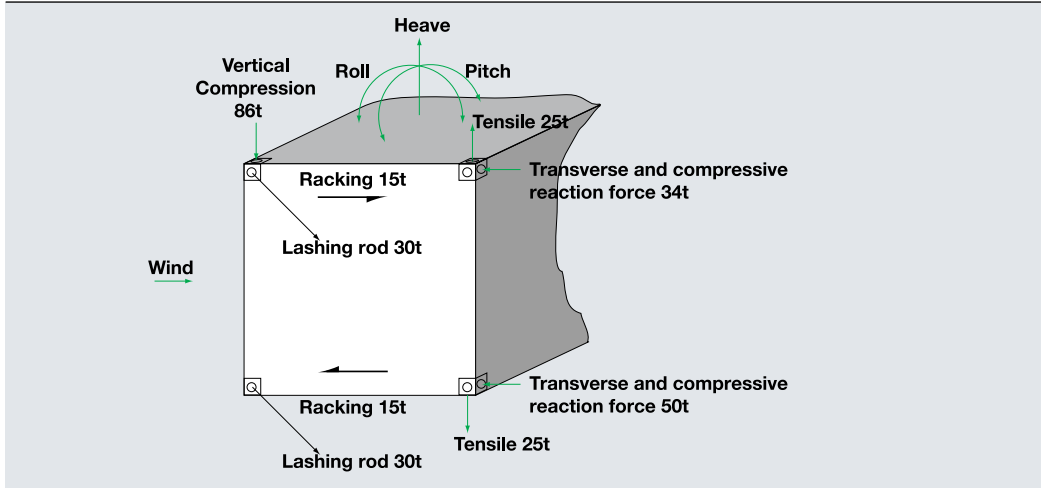

CALCULATION OF FORCES

PARAMETRIC ROLLING

The term parametric roll is used to describe the phenomenon of large, unstable rolling which can suddenly occur in head or stern quartering seas. Due to its violent nature and the very large accelerations associated with the onset of parametric rolling, there is widespread concern for the safety of container ships. Possible consequences include loss of containers, machinery failure, structural damage and even capsizing.

Parametric roll is a threshold phenomenon. This means that a combination of environmental, operational and design parameters need to exist before it is encountered.

These are:

- ship sailing with a small heading angle to the predominant wave direction (head or stern quartering sea)

- wavelength of the predominant swell is comparable to the ship's length
- wave height is fairly large
- ship's roll-damping characteristic is low

If resonance occurs between the wave encounter period and the natural, or twice natural, roll period of the ship, then parametric roll motion can be experienced.

WHY ARE LARGE CONTAINER SHIPS VULNERABLE?

Fine hull forms with pronounced bow flare and flat transom stern are most vulnerable to parametric roll. Such features contribute to the variation of the ship's stability characteristics due to the constant change of the underwater hull geometry as waves travel past the ship.

Although this phenomenon has been studied in the past, it has only come to prominence with the introduction of the larger container ships. Until the 1990s, it was considered critical only for ships with marginal stability and fine-lined warships.

CONSEQUENCES OF A PARAMETRIC ROLL

A parametric roll can have dire consequences for container securing and for operation of machinery.

It is an extreme condition for container securing since it combines the effect of large roll and pitch amplitudes. This scenario imposes significant loads on container securing systems.

In theory, the container securing system could be designed to withstand such extreme motions. The consequence would be a significant reduction in the number of containers that could be carried on deck. So, essentially, there is a balance between increased container security and the limitations imposed by securing requirements.

The extreme roll angles reached during a parametric roll usually exceed those adopted during machinery design. Indeed, it would be very difficult to bench test a large marine diesel engine at 40 degree angles. Possible consequences on machinery operation of the ship heeling to these very large angles include loss of cooling water suction, exposure of lubricating oil sumps and,

for resiliently mounted engines, problems with the connection of services – and hence shutdown of the main engine.

The following points should be borne in mind:

- parametric roll is a relatively rare phenomenon occurring in head or following seas, which is characterised by rapidly developed, large, unstable ship rolling
- risk control options exist in both design and operation of container ships that can effectively reduce the likelihood of a parametric roll occurring. Reducing the likelihood of its occurrence is considered a more effective approach than mitigating the consequences
- compliance with Lloyd's Register's current requirements for container securing systems can reduce the risk of container losses
- masters should be aware that when conditions for parametric rolling exist, ie. head/stern seas with wave length similar to the ship's length, the action of putting the ship's head to the sea and reducing speed could make rolling worse. Other action to ease the ship's motion will be necessary, depending upon the prevailing weather
- the North Pacific in winter is especially prone to these conditions



OUTBOARD CONTAINER
DAMAGED BY HEAVY SEA

12 CONSEQUENCES OF FAILURE

CASE STUDY

The consequence of failure is almost always loss or damage of containers. The club has been involved in every type of incident following container loss, from widespread pollution after a floating container hit a ship's hull and pierced a fuel tank, to wreck removal when sunken containers contained toxic chemicals, to a seaman hit by cargo falling from an open container. The study which follows graphically illustrates how simple faults, on a well run ship, can give rise to large container losses and the incidents described above.

COLLAPSED CONTAINER – CRUSH DAMAGE



It was February and the Panamax container ship had loaded in Northern hemisphere ports for China. She had seven holds and could carry over 3,000 containers, although less had been loaded on this occasion. Loading was homogeneous, without isolated stacks, but heights of containers differed. Containers were loaded on deck, five high in some bays and three high in others. Lashings consisted of base (manual) twistlocks fitted into dovetail foundations with semi-automatic twistlocks used between containers. Parallel crosslashings were applied using short and long lashing rods with turnbuckles. These connected to the top corner of first tier containers and to the bottom corner of second tier containers. Wind lashings were applied on the outboard stacks with long rods connected to the bottom corner of

third tier containers. The ship's GM was 2.0m.

The schedule required sailing south along the western seaboard of the United States before crossing the Pacific to Japan and China. The ship was on a southerly course when she encountered strong head winds with heavy head seas and swell. She was pitching and rolling heavily with occasional rolls to very large angles when a loud crash was heard. It was suspected that containers had been lost or had shifted. Next morning the extent of damage could be seen; the entire stack forward of the bridge had collapsed. Many containers remained on board but some had fallen overboard. Investigations revealed that a number of classic mistakes had contributed to the loss.

COURSE AND SPEED

The ship was proceeding on a southerly course into head seas and was pitching and rolling heavily. Rolling in head seas may be associated with the phenomenon known as 'parametric rolling' which occurs because the ship's waterplane area changes as waves pass along the ship's length. Maximum rolling can occur when a wave's length is comparable to the ship's length. At the instant when the ship's midship is supported by a wave crest, with the bow and stern in a wave trough, there is an instantaneous loss of waterplane, sudden and massive loss of righting force and the ship may roll to very large angles. As the wave passes along the ship's length the situation is reversed, strong righting forces are exerted and the ship rights herself but only to roll again as the next wave passes. Effectively, the ship performs simple harmonic motion but with violent rolling.

During the conditions of very severe rolling, containers stowed on deck can be subjected to massive separation forces, forces that are likely to exceed the combined strength of the securing system. Parametric rolling may be prevented by alteration of course or change of speed.

STOWAGE AND SECURING

The bottom container in each stack was secured by twistlocks fitted to dovetail sockets which slide into dovetail foundations. Dovetail foundations, for a variety of reasons, have a tendency to wear which can result in movement of the securing twistlock. In extreme circumstances the base twistlock can be pulled out of the dovetail foundation leaving only the lashing rods to hold containers in place, something which they are not designed to do. This had happened and as a consequence turnbuckles had pulled apart and lashing rods had broken.

One end of the lashing rod was connected to a D ring and D rings were welded to the lashing bridge for this purpose. Some of the D rings had been pulled apart and it was found that D ring securing collars had been poorly welded and were weak. Quality of welding is a matter for new build superintendents, not the ship's crew but during routine maintenance, chipping and painting, welds which connect securing points to the ship should be examined for corrosion,

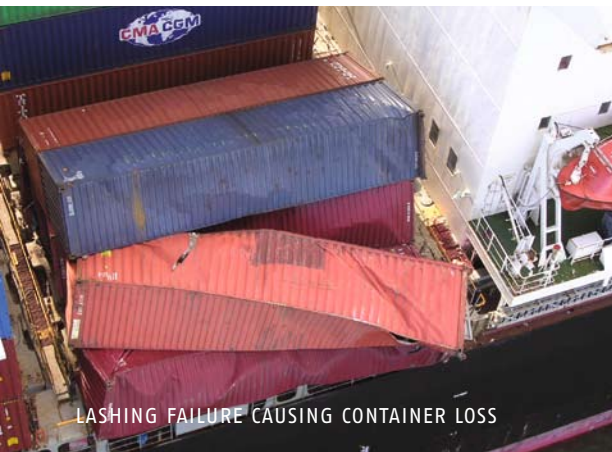

LASHING FAILURE CAUSING CONTAINER LOSS



damage or defect with any observed deficiency being reported to the master. On this ship D ring collar welds had very poor penetration and the securing point was weak.

This is not something a ship's crew can correct but an observant seaman who spots a defect and reports it can be instrumental in preventing a major loss. Base foundations need regular examination and test, something which should form part of the ship's planned maintenance procedure.

Not all base twistlocks had failed, some were found unlocked and it was suspected that the ship had been using left-hand and right-hand locks in the same stow. Using left-hand and right-hand locks in the same stow makes it very difficult to detect whether a twistlock is actually locked or open. Ship's crew should be checking for incorrectly handed locks and removing them.

The ship had been loaded in accordance with the limits imposed by class and nothing improper was found with container distribution or stack weights. However, mathematical simulation of the forces imposed on the containers during violent rolling indicated that racking and compression forces on the containers exceeded the design strength of lashings by 1.5 and 2.5 times respectively. This would have resulted in very large separation forces on the stacked containers. Prior to the incident the crew had checked that turnbuckles were evenly tightened but they had not applied additional wind lashings. Any additional lashings applied in exposed locations before the onset of severe roll and pitch conditions should improve combined lashing strength, provided the lashings are applied to the bottoms or tops of containers which are only secured by twistlocks.

With the benefit of hindsight it is seen how simple errors can cause container loss. The weather conditions experienced were not extreme but the effects of parametric rolling, worn base foundations and weak 'D' ring collars all contributed to the catastrophic loss of containers. It is rarely a single failure that results in a loss but a sequence of events. For this reason it is essential to follow best practice and the principles set out in this guide.



CONTAINERSHIPS



NNPC
Rijksstraatweg 361
9752 CH Haren (Gr.)

www.nnpc.nl
info@nnpc.nl

The Standard 

 Lloyd's
Register

Authors

Eric Murdoch, Chief Surveyor
Standard P&I Club
David Tozer, Business Manager
Container Ships Lloyd's Register

Photo cover

Wim te Brake, Amsterdam

Design

In Ontwerp, Assen